



Glassware Washer - Hot Water Sanitizing



APPLICATION

The beer, wine or distilled spirits you make is what you want your customers to taste. When your glasses or stemware are not properly cleaned and sanitized, you run the risk of tainting the tasting.

Swash Sanitizing Equipment has established itself as a leader in providing equipment and expertise to the food and beverage industry for cleaning, sanitizing, and sterilizing. Its products include steam generators, pressure washers, barrel washers and rinsers, tank washers, glassware/bottle washers, chemical sanitizers for equipment, buildings and grounds, and hand sanitizers for facility personnel and guests.

To optimize the cleaning process, Swash Sanitizing Equipment has partnered with CMA Dishmachines to offer a hot water commercial washer that does not require the use of chemical sanitizers, reducing the risk of odors or off-tastes.

PERFORMANCE

Commercial (NSF) standards of sanitization are met with the use of detergent, rinse aid and hot water. Detergent, rinse aid, and wash pumps are built-in. The washer produces hot water sanitizing through the use of a built-in 5.3kw booster heater. A safety system ensures sanitizing temperatures in the final rinse by holding the wash cycle in run mode until the final rinse temperature is detected to be in the user definable range of 180° to 195°F. This heat also improves drying. The 3/4 HP wash pump provides excellent recirculation at 38 gpm with a 2.5 gallon wash tank in line. The unit gravity drains into a floor drain. If a floor drain is not available, an optional drain pump can be included. The unit comes standard with upper and lower stainless steel wash and final rinse arms, digital LED temperature gauges and easy to operate controls.

Two models are available. One comes with universal glassracks for beer glasses, stemware - held at an angle for self-draining stem bottoms, or tasting/shot glasses. The second comes with a custom designed rack for finer crystal stemware, which holds each stem securely in place at an angle to facilitate draining and drying and minimize water spotting or need to polish.

The total cycle time with incoming hot water of at least 140°F is 2 minutes. Approximately 30 racks per hour can be processed. Water consumption is less than one gallon per cycle. A removable drain screen protects the pump from damage from debris.

The unit is designed for free standing or can be placed under counter. The cabinet bottom is elevated for easier loading and unloading. Construction is of stainless steel. The top mounted controls are easy to read and simple to operate. 6" legs are included or an optional bottom storage pedestal is available which also raises the unit to a higher level for free standing installations. The units are UL Listed and Energy Star rated for safe and efficient operation.

ORDERING INFORMATION

- DIS-16501: Washer w/ 2 universal glassware racks. (DIS-16501-BP)
- DIS-16501-W: Washer w/ 1 custom stemware rack. (DIS-16501-ARS)
- DIS-16501-D: Optional drain pump for DIS-16501 or DIS-16501-W.
- DIS-16501-PED: Optional pedestal stand with storage.
- DIS-16501-BP: Universal glassware rack, 20"W x 20"D x 4"H.
- DIS-16501-ARS: Custom stemware rack, 20"W x 20"D x 4"H.
- DIS-16501-E: Glass rack height extenders, 20"W x 20"D x 1-3/4"H.
- DIS-16501-C: Cart, portable with handle, to stack and store racks.



DIS-16501-BP

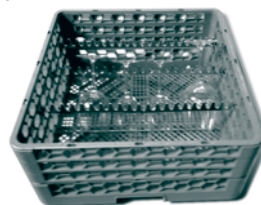

DIS-16501-ARS



DIS-16501-E



Glassware Washer - Hot Water Sanitizing

WARNING: Plumbing connections must be made by a qualified service company who will comply with all available Federal, State, and Local Health, Plumbing and Safety codes.

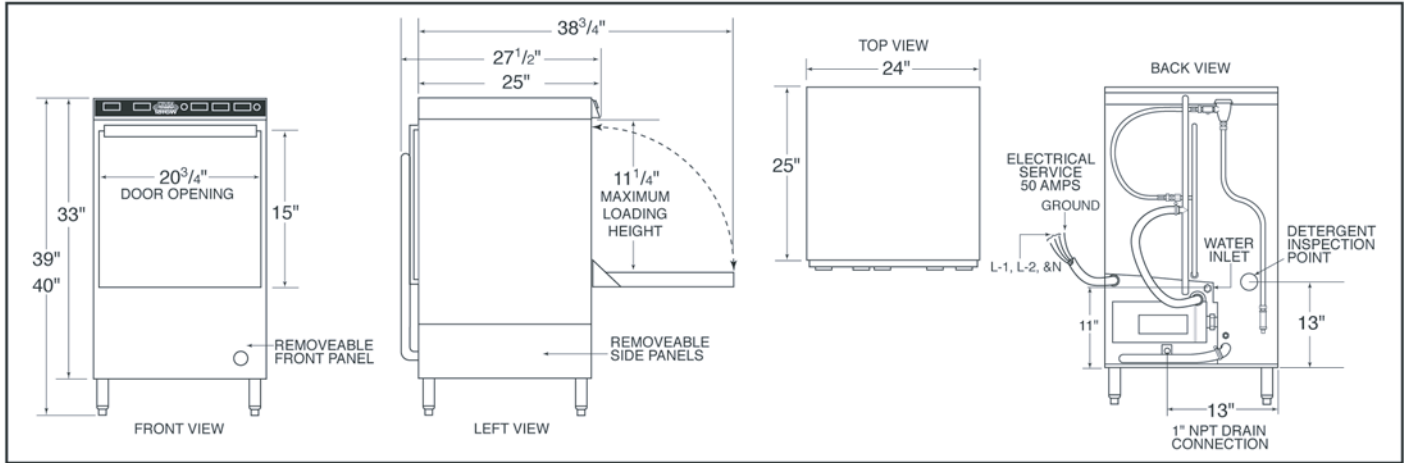

Specifications:

	USA	(Metric)		USA	(Metric)
WATER CONSUMPTION			FRAME DIMENSIONS		
PER RACK	.75 GAL.	(2.84 L)	DEPTH	25"	(63.5 CM)
PER HOUR	18 GAL.	(68.1 L)	WIDTH	24"	(60.96 CM)
OPERATING CYCLE			HEIGHT	39"-40"	(99-101.6 CM)
WASH TIME-SEC	94	94	MAX CLEARANCE FOR DISHES	11-1/4"	(28.6 CM)
RINSE TIME-SEC	16	16	WASH PUMP MOTOR	1 HP	1 HP
DWELL TIME-SEC	10	10	ELECTRICAL RATING	208 VOLTS	230 VOLTS
TOTAL CYCLE TIME	2 MIN.	2 MIN.		1 PH-60 Hz	1 PH-60 Hz
OPERATING CAPACITY			TOTAL AMPS	33.0 AMPS	35.0 AMPS
RACKS PER HOUR	30	30	BOOSTER HEATER KW	5.3 KW	6.5 KW
WASH TANK CAPACITY	2.5 GAL.	(9.46 L)	THIS SYSTEM REQUIRES THREE POWER WIRES WHICH INCLUDES A CURRENT CARRYING NEUTRAL. AN ADDITIONAL FOURTH WIRE MUST BE PROVIDED FOR MACHINE GROUND.		
PUMP CAPACITY	38 GPM	(144 LPM)	SHIPPING WEIGHT		
WATER REQUIREMENTS			APPROXIMATE	234#	(106 KG)
REQUIRED MINIMUM TEMP.*	110°F	(43°C)	*For machine having "Safe-T-Temp"		
RECOMMENDED TEMP.**	140°F	(60°C)	**For faster heat recovery		
WATER INLET	1/2"	(1.27 CM)			
DRAIN CONNECTION	1"	(2.54 CM)			
RINSE PRESSURE SET	20 ± 5PSI	1.41 KG/CM²			
CYCLE TEMPERATURES					
WASH-°F	155° F-160° F	(68.3°C/71°C)			
RINSE-°F	180° F-195° F	(82°C/90°C)			

Summary Specifications:

Provides hot water (180°F) sanitizing through the use of a built-in booster heater. 180°F final rinse safety system ensures proper temperatures in the final rinse by holding wash cycle in run mode until 180°F rinse temperature is detected. The unit comes standard with upper and lower stainless steel wash and final rinse arms, digital LED temperature gauges and easy to operate controls. Constructed entirely of stainless steel. Uses standard 20"x20" glass racks with a 12" door clearance.

Options Available:

- Stainless Steel Pedestal
- Custom Racks

